



The Strikesorb surge protection module: A new era

Abstract

The motivation behind this paper is to provide an overview of surge protection technologies for low voltage power systems and focus on some of the challenges of conventional surge protective devices that can be overcome through an innovative engineering design.

Introduction

There are several manufacturers of Surge Protective Devices (SPD) worldwide, sharing a global market that's expected to reach \$2.48 billion by 2020¹. The overwhelming majority of the SPD manufacturers use the same technology, developed some 30 or more years ago, to protect today's sophisticated electronic equipment. Their approach to surge suppression relies on using a multitude of bulk produced, commercial quality, low surge current rated metal oxide varistors (MOV) or silicon avalanche diodes (SAD) originally developed for electronic printed circuit board (PCB) applications.

With the exception of Strikesorb surge protection modules (Photo 1), there hasn't been any major technology improvement developed over the past several decades regarding the design principle, technology or performance of SPDs, also known as Transient Voltage Surge Suppressors (TVSS). Some manufacturers have added features to make the devices more attractive to the end user, but these features are irrelevant to the surge protection capabilities of the products.

Introduced to the market in early 2000, Strikesorb modules were designed from the ground up to overcome all the shortcomings of existing SPD systems. They were specially designed to protect sensitive state-of-the-art electronic equipment against catastrophically intense transient surges. Strikesorb surge protection modules provide the ultimate protection to sensitive equipment loads. They can be trusted to protect at all times and under the most severe service conditions. Strikesorb modules look different and perform differently than their conventional counterparts. They have

been deployed worldwide and have been performing under the most extreme environmental conditions. They boast an excellent and proven track record and have succeeded where every other SPD has failed.

These successes have encouraged many key customers to enter into strategic alliances with Raycap Corporation, the manufacturer of Strikesorb, to use the Strikesorb modules in their own applications. Numerous other equipment manufactures (OEMs) have integrated them into their own products as well.

The Strikesorb technology is protected worldwide by several patents. Raycap continuously strives to improve the product and increase its capabilities as industry needs intensify and standards organizations sharpen their performance and safety requirements.

Challenges for conventional technologies

1. Poor design parameters and misleading assumptions

Conventional surge protection designs call for placing multiple components in parallel arrays, in theory to enable the SPD to conduct higher surge current values. These components are typically soldered into printed circuit boards (PCBs) with wire leads that are angled with 90 degree bends to accommodate the population of the board. It is common practice for SPD manufacturers to multiply the surge current capacity of each individual suppression component by the number of parallel components to report the finished product's total surge current capacity. Unfortunately, while that calculation may sound reasonable, it is simply not accurate by any engineering principle.

In theory, it would be possible to match suppression components, but this would need to be accomplished across the complete range of operation of the component and would therefore be prohibitively expensive or even catastrophic for the individual components given that these components are highly non linear. Even semiconductor devices fabricated on the same wafer vary in performance due to minor defects and/or impurities in the lattice of the semiconductor material.

Poor mechanical design can lead to one individual suppression component consistently having to withstand more energy than its neighbors during a surge event. As a rule, an electrical transient takes the shortest and most conductive path that is available. In addition, when it goes around corners, it exerts (Lorentz) forces on the current carrying conductors. The net result is that for large transient currents, such as those produced by lightning, SPD devices can fail violently or explode as these forces and energies dissipate through one component rather than being equally shared by all of the parallel components. This is depicted in photos 2 and 3 on the following page.

¹ Global Industry Analysts, Inc.; "Global Surge Protective Devices (SPDs) Market Trends, Drivers and Projections."; www.strategy.com.



Photo 1: Strikesorb Modules

There are several SPD products that attempt to accomplish equal path lengths for their parallel connected surge protection components. While these products offer some increased resistance to transient events, they tend to be plagued by longer duration surge anomalies as their performance characteristics are adversely affected by temperature. The surge suppression components that are employed by conventional SPD designs, by no means, have the same capability to equally dissipate transient surge energy as heat.

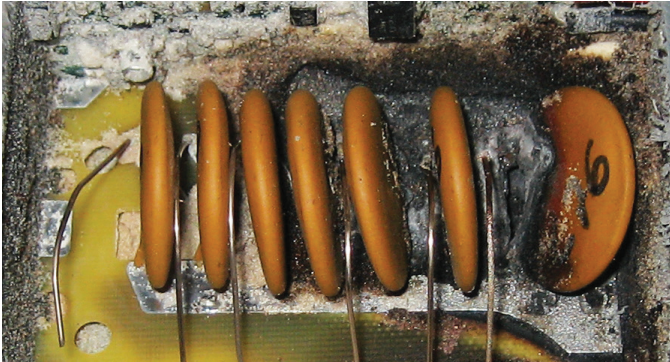

Photos 2 & 3: Exploded Modules - Do these pictures look familiar to you?

2. Inadequate rating

It is extremely important to properly identify the threatening aspects of transient surge events. Failure to do so will result in improperly applied SPD equipment. SPD manufacturers routinely make product claims that are pointless and are not supported by actual testing. They ultimately lead to the purchase of SPD equipment that will not perform as anticipated.

For example, manufacturers of the very expensive silicon avalanche diode (SAD) based surge suppressors routinely boast of their product's exceptionally fast response time. They neglect to explain that while that may be true at the component level, the true response time of the finished suppressor product deteriorates dramatically after leads are attached to the individual suppression components to allow for their placement on PCBs, and as fusing is incorporated in the suppression circuits to prevent failure modes. It is surprising to see how often low current rated fast blow fuses are used to protect the more exotic SAD based surge suppressors.

The argument to support the use of a fuse is that the transient is so fast that the fuse will not have time to operate. Unfortunately, this is a false argument. Fuse operation is

based on getting sufficient energy into it to open its link. It can be easily shown that a typical 35-A, fast blow fuse requires only 850A of a 100 μ s square impulse current to open. The same fuse requires only 3000 Amps of a shorter duration 10 μ s square impulse current to open. The bottom line is that any fusing that is incorporated in any SPD system will be affected by the current that passes through it. Whether the fuse opens or not is determined by the intensity as well as the duration of the surge current.

The energy contained in an 8/20 μ s lightning surge waveform is very similar to that in a 10 μ s square wave. It quickly becomes clear that any excessive current handling claims for these devices are unfounded. The need to fuse any surge protector at this low level is an admission of failure by the SPD manufacturer.

3. Lack of testing or inappropriate testing

Very few claims made by SPD manufacturers are tested. Most manufacturers have only limited test equipment and laboratories.

SPD equipment is generally tested to 10kA 8/20 μ s surge current waveforms. However, the test results are often extrapolated and quoted in very high overall kA ranges. It is common for SPD manufacturers to report their products' surge current capacity at 500kA, or even higher. Expecting these conventional surge suppressors to actually be able to support their suppression claims are at best, wishful thinking. More often than not they are blind guesses.

Inappropriate testing is often performed while testing parameters and test results are misquoted. For example, testing to UL 1449 offers no indication at all that any useful transient suppression can be obtained. What UL 1449 does do is to indicate that if the SPD product is installed in exactly the same way the product has been tested, then the risk of fire or explosion has been minimized – it is a safety standard. No surge suppression performance parameters are indicated other than the suppressed voltage rating (SVR) as the suppressor conducts 500 Amps of surge current.

While a product having UL 1449 is a reasonable base indicator that can be used to begin product comparisons, it doesn't provide the end user enough information to adequately assess the performance characteristics of competing suppressor products. The reality in practical applications is that exposure of electronic equipment to such low level surges is hardly harmful at least in the short term.

A suppressor that reports a relatively low SVR at 500 Amps may exhibit far greater let-through voltages as it is called upon to conduct much higher and more realistic real-world values of surge current. Conformance to UL 1449 does not mean that fire and explosion will not take place, but only that it will be contained within the SPD outer enclosure.

The only way to guarantee safety under fault current conditions is if the surge protection components inside the finished product have been individually tested under the same conditions. The necessity of drilling holes in the box to accommodate installation cables can allow fire and smoke to escape the enclosure during a catastrophic failure mode.

Suppressor tests are typically conducted using very short cables that do not accurately correspond to how they are installed in their real world applications.

4. Fusing

The reason for fusing conventional surge suppressors is twofold. One is to allow the SPD to protect itself from being damaged by intense surge currents and the other is to preclude the suppressor from starting fires should it fail. SPD suppression circuits are typically fused in order to provide a means for the product to electrically remove itself from the AC power distribution should they be called upon to conduct surge current values that exceed their capabilities. Fusing, as it is applied to surge suppression circuits, can certainly be an indication of a product's inadequate surge current handling capability.

Thermal fuses are known to have reliability issues with use and over time. The same thermal fusing technology, featuring low melting point metals supported in wax and that are also used in coffee pots, are used in some SPD products. Experience with these fuses shows that they simply wear out and have to be replaced periodically to maintain normal operation. Another type of thermal fuse is constructed with low melting point solder that is held in tension by a spring. These devices are problematic because solder cracking develops as they age over time and they tend to open for no apparent reason.

Improper fusing techniques not only compromise the suppressor's performance capabilities, but they contribute to failed SPD equipment and more importantly can cause failures to the protected electronic equipment. The surge protector will always be rendered useless whenever its fuse clears. Conventional and thermal fuses both suffer aging from mechanical shock, as well. Mechanical shock can be created by transients during the operation of the SPD. Studies have shown that fuses are progressively weakened by transient currents, and so the reliability of the protector is reduced as a result.

5. End-of-life failure mode

Even though it is not the best course of action, the electronics industry accepts the end-of-life of a surge protection component to be an open circuit. Therefore, the failure mode of conventional SPD components has been routinely designed towards open circuit conditions. Typically, a fuse is utilized to disconnect the SPD from the circuit under adverse current conducting situations. This is alarming in that a critical load, which is supposed to be secured by the SPD, is now left to deal with the full force of any power surge without protection simply because the protector "has managed to protect itself" by opening its fuse to leave the equipment exposed.

Protected equipment loads are better served with surge protectors exhibiting the exact opposite end-of-life mode. They should be designed towards short circuit conditions and should they fail, they should do so in a shorted state. While the failed SPD may have high current circulating through it as it crowbars the power source, the voltage across the device will be reduced to a very low level. Even in this state, the SPD fails in a safe manner because it will clear the line fuse or disconnect and disable AC power to the entire circuit.

Such a device has to be able to crowbar high prospective currents and safely open line fuses in the order of several hundred to several thousand amperes. It also has to be so reliable that the possibility of it actually failing is minuscule, to preclude the nuisance tripping of the line disconnect.

Therefore, this unconventional SPD would have to be capable of dissipating significantly higher energy values from transient surges and from line swells than was previously achieved by conventional SPD equipment. While installation instructions commonly use phrases like "keep the leads as short as possible", and "use a large diameter wire", etc., they interestingly don't usually mention the adverse effects that inductances associated with connection leads and internal fusing have on the SPD system.

6. Installation Method

There are two basic SPD installation configurations, the "T" or "branch" and the "Direct" or "Kelvin" connections that are illustrated in Figure 1.

With the "T" connection the load is exposed to the sum of the voltage drop across the inductance of the lead wires, the SPD fuse, and the clamping voltage of the SPD. On the other hand, in the Kelvin connection the load voltage is limited to the let-through voltage of the SPD irrespective of the length of the lead wire as shown in Figure 1. It is easy to conclude that the "T" connection is the least desirable connecting option since the Kelvin connection completely eliminates the lead inductances. Therefore, the "Direct" or Kelvin connection is the preferred means to connect the SPD in a way to provide the utmost levels of protection for sensitive electronic loads.

Most conventional SPD products are not designed to accommodate the Kelvin connection option. As a minimum a well-designed SPD system should be designed in a way, as to facilitate both T-branch and Direct (Kelvin) connections. The decision on how to install the SPD is always taken by the end user, taking into account the detailed requirements of the application.

Direct (Kelvin) Connection

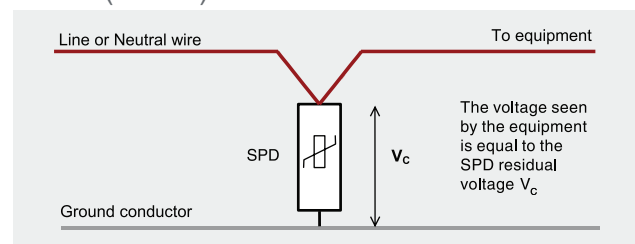

Conventional T-Connection

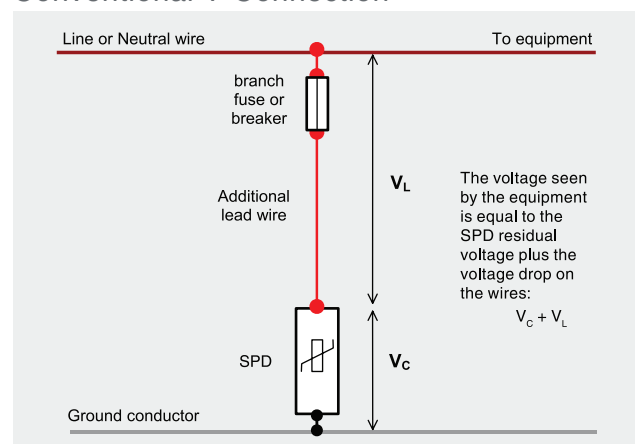

Figure 1: Residual voltage in Kelvin and T-connection applications.

6. Fire and Safety Issues

It was previously mentioned that surge suppression components can exhibit arcing and burning during catastrophic modes of failure. The 1998 version of the UL 1449 safety standard attempted to put tests in place to identify abnormal SPD failure modes.

An abnormal overvoltage short circuit current test was introduced. During this test, the voltage across a SPD is twice its nominal operating level.

Overvoltage is maintained at that level for seven hours while the SPD is called upon to conduct 5 Amps rms AC current for the duration of the test.

The extended purpose of the test was to observe the failure mode of the protection device and to insure that no fire or smoke was generated as a result.

Almost every manufacturer of 1998 version of UL recognized or listed SPD equipment incorporated internal fusing that was sensitive to the 5A current and which would disconnect the SPD from the circuit after a short period of time.

UL revised the 1449 safety standard in 2005 as the industry became aware of potentially dangerous failure modes with regard to listed or recognized suppressor products.

Significant changes, which became effective on February 9, 2007, extended the limit of the abnormal overvoltage short circuit tests from 5A to 1000A.

These tests are destructive trials that necessitate the SPD to either safely conduct the fore mentioned current values for seven hours or to disconnect themselves from the test circuit before fire or shock hazards develop.

Conventional SPD technologies typically continue to rely on thermal and overcurrent fusing to comply to the revised UL 1449 requirements.

The revised standard, that requires intermediate current testing levels at 100, 500 and 1000Amps, complicates the design considerations of the fusing or thermal disconnection mechanisms.

The engineering approach many manufacturers may take is to make the disconnection mechanism react to these currents rapidly to prevent the full amount of the current from passing through the surge suppressor.

However, a more sensitive disconnect makes the surge protector more vulnerable to failures from surge currents. Eventually, the suppressor's performance capabilities are sacrificed to meet the more stringent UL safety requirements.

An engineered remedy

The requirements for a reliable surge protector can be summarized as follows:

The protected load should never be exposed to damaging transients/surges regardless of the condition of the protector.

- The protector should operate in such a way as to preclude safety risks with regard to smoke, fire, and explosion without sacrificing any of its performance capabilities.
- The reliability and lifetime of the protector has to be greater than those of the equipment/load being protected.
- The protector should be able to continuously protect critical equipment loads under all abnormal line conditions and at all times.

These requirements translate into the following "desirable" protector features:

- No flammable material should be used in the protector. For example, no potting material.
- The protector must be physically robust in order to sustain high amounts of energy without disintegrating.
- The protector should not require any internal fusing in order to meet the UL 1449 safety standard.
- The protector should become a short circuit at its end of life.
- The protector must be capable of installation using either the "Kelvin" method or the "T" configuration, if desired.
- The protector should exhibit a life span of several years in a surge exposed environment without maintenance requirements.
- The protector should be able to dissipate absorbed transient/surge energy safely without undue heating.
- The protector should exhibit minimal internal dynamic resistance and minimal inductance.

The Strikesorb surge protection module shown in the Photo 4 is designed to meet the above requirements.

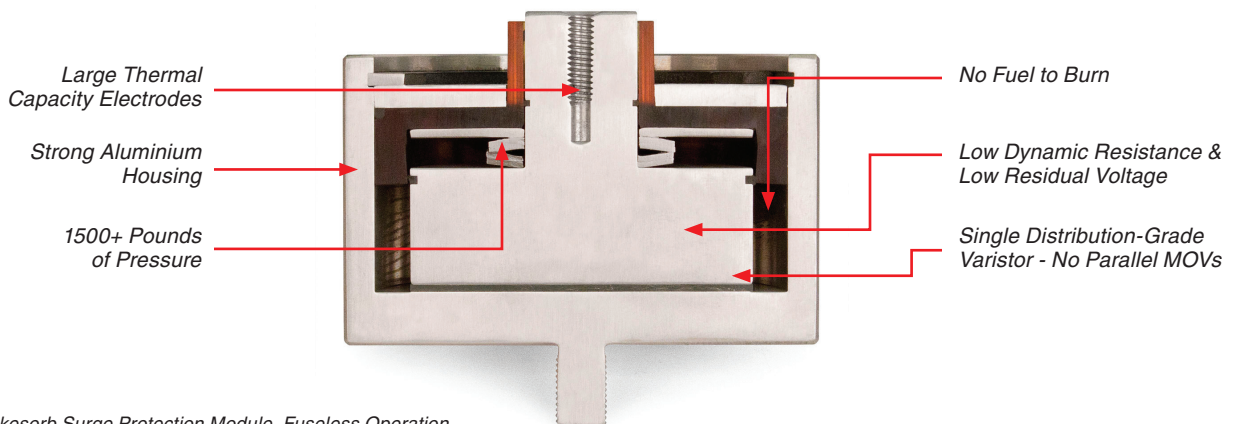

Photo 4: Strikesorb Surge Protection Module, Fuseless Operation

Strikesorb design features

Mechanical

Each Strikesorb protector is constructed with a single 30mm, 40mm or 80mm distribution grade zinc oxide varistor (MOV) that is housed inside a robust, hermetically sealed metal casing. No potting or other flammable materials are utilized by the protector or contained within the casing. The zinc oxide varistor is placed between two electrodes that exhibit high thermal capacity and conductivity characteristics. The disk is not rigidly placed between the electrodes, but held under a high pressure to overcome the Piezoelectric and Lorentz forces that occur during surge events.

The heat generated within the zinc oxide varistor disk efficiently dissipates into the environment via its electrodes and into the connected busbars/metalwork via the device casing.

The high thermal conductivity of the materials used also ensures that any temperature rise within the varistor is minimal. Strikesorb modules are designed to remove 1000 times more thermal energy than conventional SPD products.

The lower temperature rise in the Strikesorb's suppression component dramatically extends the product's life expectancy and prevents ageing of the zinc oxide material.

Thermal runaway problems are precluded as the electrode acts as a heat sink, smoothing out any heat gradients across the minor surface imperfections of the amorphous crystalline MOV material.

Electrical

Strikesorb is designed to accommodate minimal inductance connections while at the same time maximizing the capacitance of the varistor disk. Its design is characterized by coaxial symmetry that results in a device that exhibits minimal impedance characteristics and minimal response time. Conventional varistors that utilize thin wire leads and even thinner electrodes are plagued by current 'hogging' phenomena resulting from their uneven current paths. Their surge current capacity decreases and they are prone to developing hot spots that ultimately cause them to fail as they are stressed by surge events. The thickness of the electrodes employed by Strikesorb on the other hand, ensure that the current conducted through the varistor is planar/parallel (uniform) and that no current 'hogging' occurs. Figure 2 illustrates this point.

In conventional MOV components, the lengths of the current paths that are employed by the individual current filaments vary considerably, leading to a number of effects including current flowing towards the outer edge of the varistor being restricted due to more resistive current paths in that region. The transit time of the current traveling through the longer paths is also higher, reducing the MOV's surge current capacity to below the levels it should be able to support. Current conducted through the component is more intense between the connection pins, as it is unable to take advantage of the total volume of the varistor. As a consequence, higher clamping voltages are realized as the MOV deteriorates and until it ultimately fails.

Strikesorb overcomes this deficiency by essentially equalizing all current conduction path lengths to allow evenly distributed current flow throughout the entire conductive surface area of its zinc oxide varistor. For all practical purposes, the Strikesorb's varistor conducts current evenly at all frequencies and utilizes the entire disk surface – volume during current conduction conditions.

Conventional Varistor

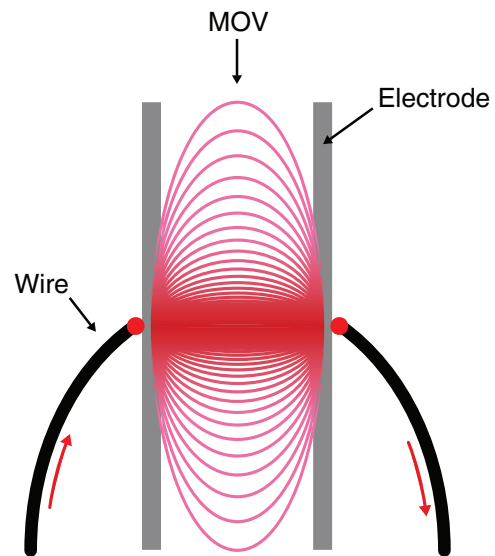

Strikesorb Modules

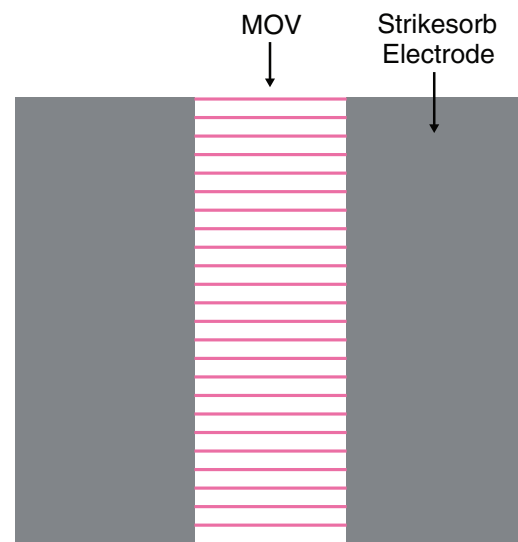

Figure 2: Current distribution in conventional and in Strikesorb modules.

Table 1: Features and benefits of the Strikesorb module design.

Strikesorb Features	Benefits
Strong Metallic Housing	This prevents fire, smoke, and explosions and allows efficient heat management and thermal energy removal from the varistor, resulting in extended life time. It enables high energy handling capability and provides the module's robustness and excellent performance under vibration conditions.
Single Distribution Grade Varistor	The single distribution grade varistor design enables a larger MOV of better quality material. A homogeneous wafer can handle higher energy surges and eliminates unequal current sharing discrepancies that plague conventional multiple varistor SPD designs.
Large Metallic Flat Electrodes	Ensure better contact points and lower contact resistance, resulting in more efficient cooling characteristics by maximizing the use of the full MOV surface area.
Varistor Under Spring Compression	Precludes Lorentz forces from crushing the varistor, ensures good contact and lower resistance at electrode interfaces resulting in lower clamping voltages. Ensures a short (fail safe) end-of-life mode.
No Fuse	Provides lower clamping voltages, enables direct (Kelvin) installation and no maintenance is required.
Cylindrical Symmetrical Design	The design reduces the inductance of the module, reduces the let-through voltage and increases the mechanical strength of the connection leads. It ensures the fastest possible response time and enables Strikesorb to avoid the majority of the Lorentz forces since the surge current does not go around corners. The design uses the entire surface of the disk when conducting surge current.
Environmentally Sealed	This allows installation anywhere without affecting performance. The varistor is not potted in combustible polymeric material that can cause smoke and provide fuel for fire.
Integration Capability	Strikesorb modules have successfully passed a UL defined three-cycle testing at available short circuit currents of up to 100,000A rms. This enables Strikesorb to be integrated within panel boards, switchboards, switch gear, motor control centers, etc, without conducting additional UL testing to check coordination with the upstream breaker. The Strikesorb module's unique fuseless design allows it to be directly installed on the busbars while precluding the need to install additional fuses or interconnection wires. Strikesorb modules have also been successfully tested to UL 1449 at 200kA available fault current behind a 4000A fuse.
Tested Performance	Specifications are backed by reputable independent laboratories' test reports, and modules are tested in accordance with all applicable SPD standards.
UL Recognized	This enables installation outside of a dedicated SPD enclosure in OEM integrated applications and specifies that the modules meet the new requirements, having been thoroughly tested to the latest UL 1449 Standard (5 th Edition), unlike many other recognized components.
IEC Compliance	Strikesorb modules have been certified by VDE as Class I SPD products, according to IEC 61643-11.
Patented	World wide protection.
Warranty	Backed by a solid 10 year replacement warranty.

Electrical verification testing

Raycap backs the Strikesorb module's stated performance characteristics with electrical test reports that verify all safety and performance claims. SPD testing is conducted in accordance with established and broadly accepted international standards including, but not limited to, those defined by IEEE C62, IEC 61643-11, UL 1449 5th (the latest as of this printing) Edition and NEMA-LS1.

The three-cycle test confirms the Strikesorb module's exceptional energy handling capabilities. Strikesorb is the only SPD available in the market that can continuously conduct a power distribution's full available short circuit current for three cycles in a safe manner. Conventional SPD equipment utilize fusing or other disconnect mechanisms that will either be unable to clear the fault current and cause the SPD to fail catastrophically, or disconnect the SPD from the power system long before the upstream circuit breaker opens, in any case leaving the load unprotected.

Strikesorb modules have been subjected to the Abnormal Overvoltage – High Current Test for three continuous cycles of abnormal overcurrent. The Strikesorb modules were connected in series with no overcurrent protection devices. Strikesorb conducted the full available short circuit current of the power source for a period of three complete cycles (50ms) without failing catastrophically. Strikesorb 40-A was successfully tested to withstand an available short circuit current of 100,000A rms symmetrical for three cycles. The three-cycle testing provides the Strikesorb modules with a unique advantage when it is utilized in integrated applications. For example, Strikesorb 40-A modules can be directly connected on the load side of any circuit breaker regardless of its nominal current rating, provided that the available fault current does not exceed 100,000A rms symmetrical.

Strikesorb modules have been tested behind a 4000A class L time delay fuse at an available short circuit current of 200,000A rms. The Strikesorb module has been exposed to abnormal overvoltage conditions that are defined in the UL 1449 5th Edition safety standard. The Strikesorb modules sustained the full short circuit current of the power source until the upstream fuse interrupted the circuit.

The above figures clearly demonstrate the unique energy handling capabilities of Strikesorb which translate into huge operational and cost savings, over the lifetime of the product, ease of installation inside panel boards and switch

gear equipment, unparalleled performance under extreme conditions and even lower initial acquisition cost due to its capability to be installed without an additional overcurrent protector directly on the main power conductors.

Safety testing according to UL 1449 5th Edition

Strikesorb is the only UL recognized SPD which has successfully gone through the complete revised testing procedure of the new UL 1449 5th Edition standard, including abnormal overvoltage testing at low and intermediate short circuit currents up to 1000A rms for 7 hours.

Therefore, unlike other UL Recognized components, its integration inside panel boards, switchboards, switch gear cabinets, motor control centers, etc, is inherently safe and will never pose a threat to the rest of the equipment. In addition, due to the fact that Strikesorb has been fully tested to the complete testing procedure as defined in the revised UL 1449 standard, panels which include Strikesorb modules do not need any further testing according to UL 1449 in order to be UL Listed. This saves the integrators and panel manufacturers a significant amount of time and money.

Due to the recent drastic changes of UL 1449, most SPD manufacturers would face a situation where systems used until now would lose their UL Listing. Under the provision of the National Electrical Code (NEC) whenever a SPD is installed it must be a UL Listed device. System integrators, specification engineers, infrastructure contractors and OEM's, need to pay attention to make sure what they are using is a UL Listed device.

Field experience

Laboratory tests are essential to help assess a surge suppressor's performance capabilities under somewhat sterilized conditions. However, lab tests are not necessarily designed to provide an adequate means to compare the performance of different SPD products as they may be tested at different times and locations. The real measure of a successful suppression technology is its performance in real world applications. No claim is worth much unless it translates into better protection levels and maintenance free operation for the customers' equipment.

Table 2: Performance capabilities of some popular Strikesorb modules.

Performance Parameter	Strikesorb 80	Strikesorb 40	Strikesorb 30
High Current Impulses	200kA – 8/20µs 2000 × 10kA – 8/20µs 25kA – 10/350µs	140kA – 8/20µs 2000 × 10kA – 8/20µs 12.5kA – 10/350µs	60kA – 8/20µs 2000 × 10kA – 8/20µs
Short Circuit Current Rating UL 1449	200kA with upstream fuse of 4000A and three-cycle testing at 65kA	200kA with upstream fuse of 4000A and three-cycle testing at 85kA	100kA with upstream fuse of 600A and three-cycle testing at 42kA
Energy Handling	250 × 1000A @ 2000µs (2500J/impulse)	250 × 500A @ 2000µs (1250J/impulse)	250 × 250A @ 2000µs (625J/impulse)

In order to prove their worthiness, Strikesorb modules were initially deployed in environments that were plagued by the worst possible power quality, worst case lightning scenarios and where conventional SPD products were unable to survive. This strategy resulted with a significant number of units being put into service throughout South America, Southeast Asia, and in notoriously troublesome locations in North America and Europe. Due to enormous success stories that were reported back from the field, Strikesorb modules were deployed on a much wider scale, with hundreds of thousands of protectors currently installed worldwide.

Strikesorb success stories are plentiful. For example, a mountain top telephone relay facility in South America had been fraught with repetitive equipment failures. Furthermore, numerous disastrous SPD failures culminating in fires and explosions had also occurred at that facility. The SPD failures were not confined to a single SPD product or manufacturer, as several different products supplied by several different manufacturers all suffered similar fates.

The power quality at this site was so bad during the lightning season that conventional SPD systems were self destructing after being placed into service for only a few days. The best of these SPD products only survived on this site for 10 days. That was before a Strikesorb equipped Rayvoss surge suppression system was employed to protect in place of the failed SPD products. It is noteworthy that the situation on the mountain top immediately changed from that point. While power quality at the site continues to be dire, that same Strikesorb based SPD system has remained in service for several years without interruption. More importantly, critical equipment failures have been eliminated. The only engineering work performed to install the Rayvoss system was to arrange for a "Kelvin" type connection at 200A per phase.

A more recent example cites the case where the PLCs controlling conveyor belts within a European surface coal mine were routinely damaged from both lightning induced surges and switching transients. Those failures interrupted mine production and dramatically increased its operational costs. Conventional SPD products were tried and rejected as they were unable to resolve the problem.

Strikesorb equipped Rayvoss SPD systems were then installed at the mine as part of a field trial. Because they succeeded where the others failed, all of the critical equipment located throughout the entire mine is now protected with Rayvoss surge suppressors. The payback period for that investment was less than one year.

Figure 3 shows the results of the study performed on-site before and after the installation of the Rayvoss unit.

Due to its unique design features and its exceptional field performance, the Strikesorb technology has been adopted by several large organizations for their operations.

Strikesorb based systems have been installed in various applications for organizations including: the U.S. Federal

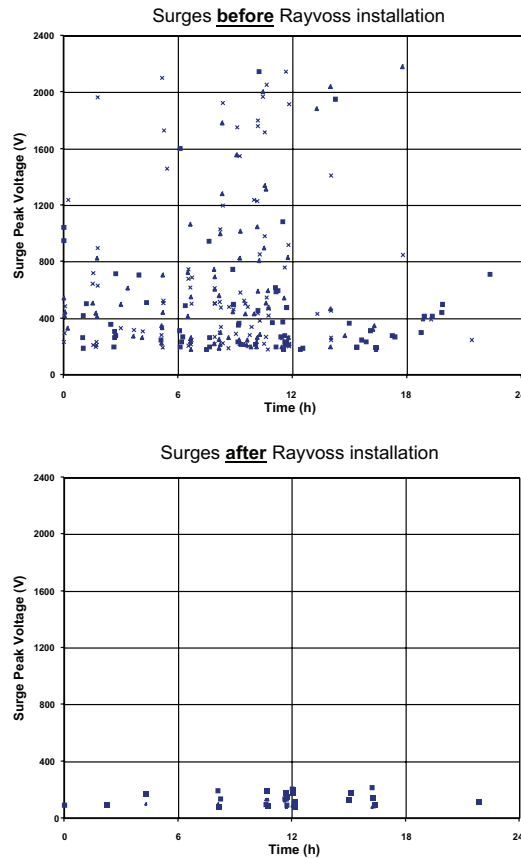

Figure 3: Power line transient overvoltages in a conveyor belt PLC measured in a 24 hour period before and after installing Rayvoss.

Aviation Administration (FAA), AT&T Mobility, Verizon Wireless, Telefonica Movistar, América Movil, Vodafone, T-Mobile, Telmex, Vestas, General Electric, Iberdrola Group, Clipper Windpower, Fuhrländer, SMA, Schlumberger, Toshiba, Rockwell Automation, Raytheon, Rolls-Royce, Siemens, Schneider Electric, Lafarge Group, Bell Canada, Telus Mobility, Telecom Italia, Wind, Cosmote, OTE, Cablevision, among others.

Conclusion

Understanding the root causes of conventional protector failures led to Strikesorb, a new generation of Surge Protective Devices based on a completely new concept. During the last few years, this technology has been deployed in a large variety of applications worldwide with remarkable success. Its unique characteristics, the ease of application and installation as well as its stellar performance in the field worldwide, has definitely created a new era in surge protection.

Raycap

www.raycap.com